

# X40-V X45-V

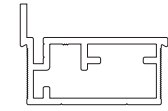

SERIES 45°

XINRIX  
DOOR SYSTEMS

# X40-T X45-T

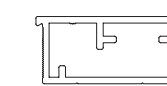
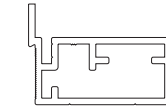

SERIES 90°

XINRIX  
DOOR SYSTEMS

## X...-VIR - EU Rechts / droit / right

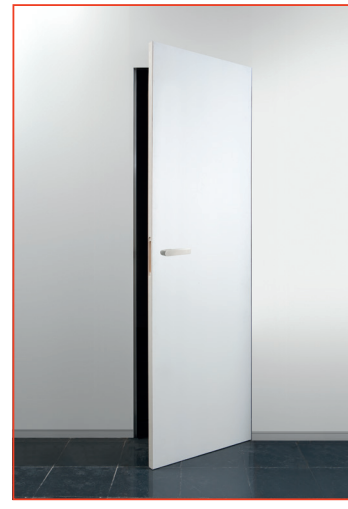

R

DUWEND EU RECHTS  
POUSSANT EU DROIT  
PUSH EU RIGHT  
DRÜCKEN DIN RECHTS

TREKKEN EU RECHTS  
TIRANT EU DROIT  
PULL EU RIGHT  
ZIEHEN DIN RECHTS

R.



R.



## X...-VIL - EU Links / gauche / left



L

DUWEND EU LINKS  
POUSSANT EU GAUCHE  
PUSH EU LEFT  
DRÜCKEN DIN LINKS

TREKKEN EU LINKS  
TIRANT EU GAUCHE  
PULL EU LEFT  
ZIEHEN DIN LINKS

L.



L.

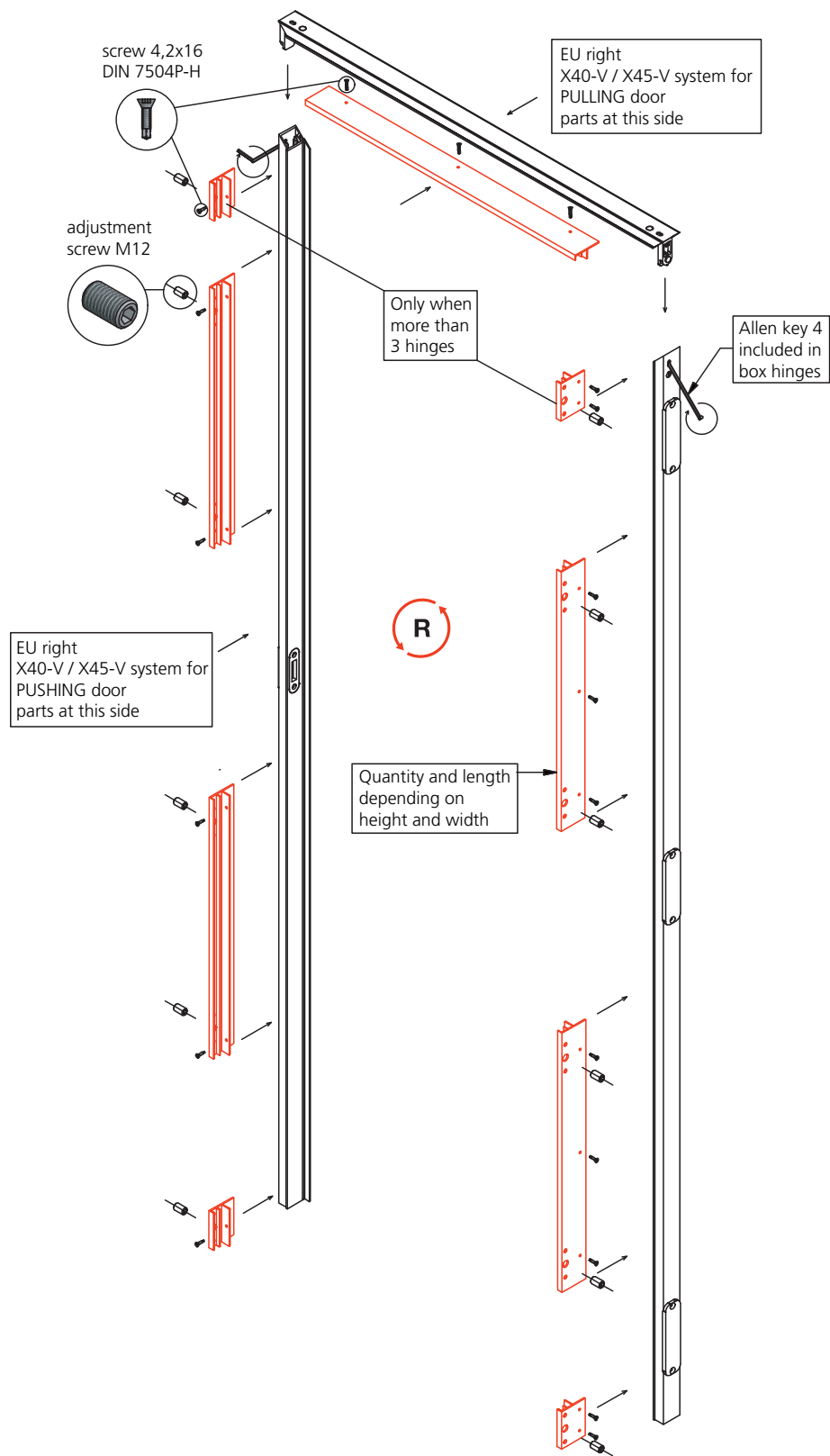

## X...-T

L-R



DUWEND EU RECHTS  
POUSSANT EU DROIT  
PUSH EU RIGHT  
DRÜCKEN DIN RECHTS

R.



TREKKEN EU RECHTS  
TIRANT EU DROIT  
PULL EU RIGHT  
ZIEHEN DIN RECHTS

R.



DUWEND EU LINKS  
POUSSANT EU GAUCHE  
PUSH EU LEFT  
DRÜCKEN DIN LINKS

L.



TREKKEN EU LINKS  
TIRANT EU GAUCHE  
PULL EU LEFT  
ZIEHEN DIN LINKS

L.

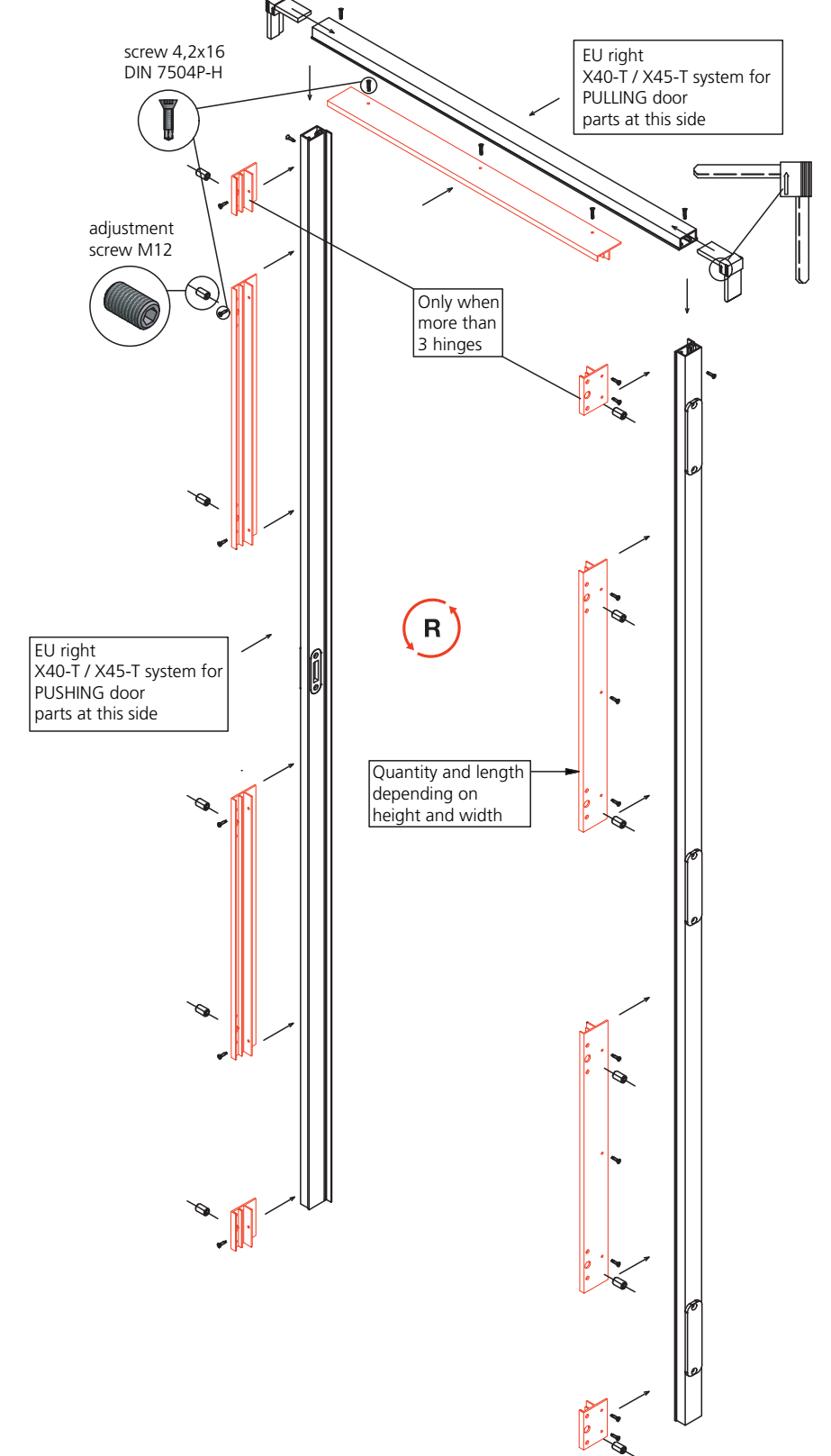



Het deurgeheel is klaar voor montage in de wand.  
L'ensemble est prêt pour installation dans le cloison.  
The door and frame are ready for installation in the wall.  
Alles ist fertig zum montieren im Wand.



Zet het deurgeheel in de wand.  
Installez l'ensemble dans le cloison.  
Install the door and frame in the wall.  
Montier das Türblatt mit die Zargen im Wand.



Controleer of deur en frame in lijn liggen met de wand.  
Contrôlez la linéarité de la porte avec le mur.  
Check if the door is perfectly in line with the wall.  
Überprüf ob das Türblatt mit den Wand ausgerichtet ist.



Met de stelschroeven kan u het deurgeheel waterpas stellen.  
Ajustez l'ensemble en utilisant les vis d'ajustage.  
Adjust the door frame using the adjustment screws.  
Das Türblatt nachstellen mit die Stellschrauben.



Bevestig het geheel met schroeven in de wand.  
Fixez l'ensemble avec des vis dans le cloison.  
Screw the door frame with the appropriate screws in the wall.  
Schraub alles fest mit Schrauben im Wand.



Fixeer met PUR-schuim.  
Fixez l'ensemble avec du mousse PUR.  
Fix with PUR foam.  
Fixier mit PUR Schäume



Werk de achterzijde af in lijn met de muurdikte.  
Finir l'épaisseur du mur aligné avec le mur.  
Finish the wall thickness according the finished wall.  
Fertig die Hintenseide ausgerichtet mit den Wand.



Onze deur is klaar voor gebruik.  
La porte est prête à l'emploi.  
The door is ready to be used.  
Das Türblatt ist fertig zum benutzen.

**X40** X40 - universal kit for standard door sizes - 40 mm  
**X45** X45 - universal kit for standard door sizes - 44 - 45 mm

2015



Plamuur  
Enduisage  
Verspachtelung  
Bending

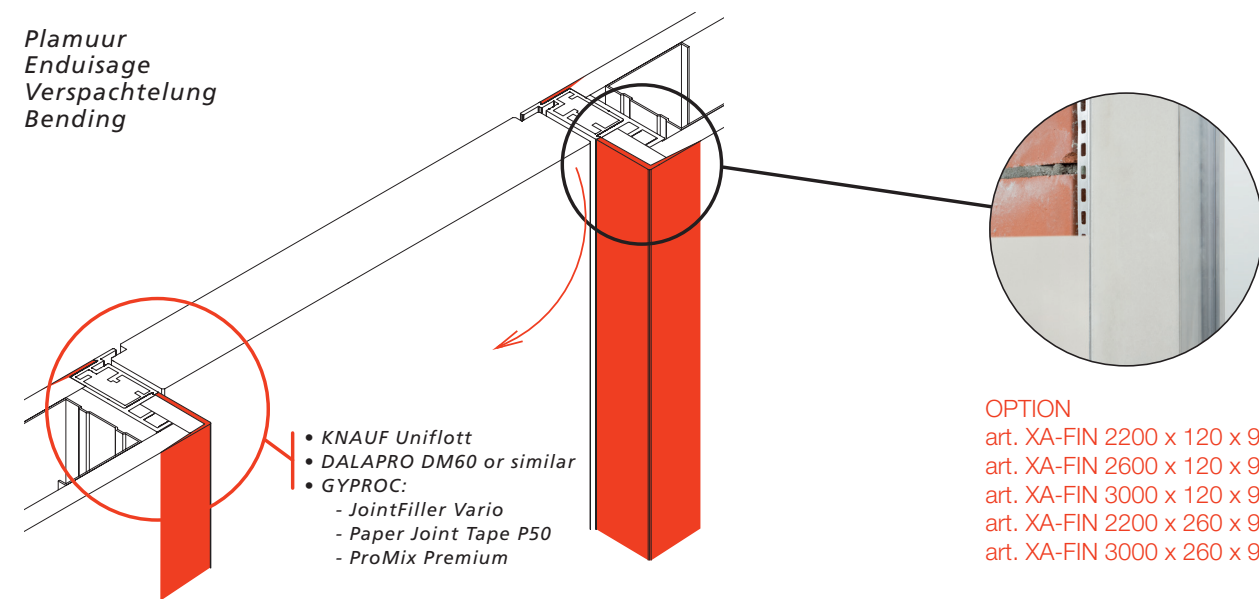

- KNAUF Uniflott
- DALAPRO DM60 or similar
- GYPROC:
  - JointFiller Vario
  - Paper Joint Tape P50
  - ProMix Premium

OPTION  
art. XA-FIN 2200 x 120 x 9  
art. XA-FIN 2600 x 120 x 9  
art. XA-FIN 3000 x 120 x 9  
art. XA-FIN 2200 x 260 x 9  
art. XA-FIN 3000 x 260 x 9

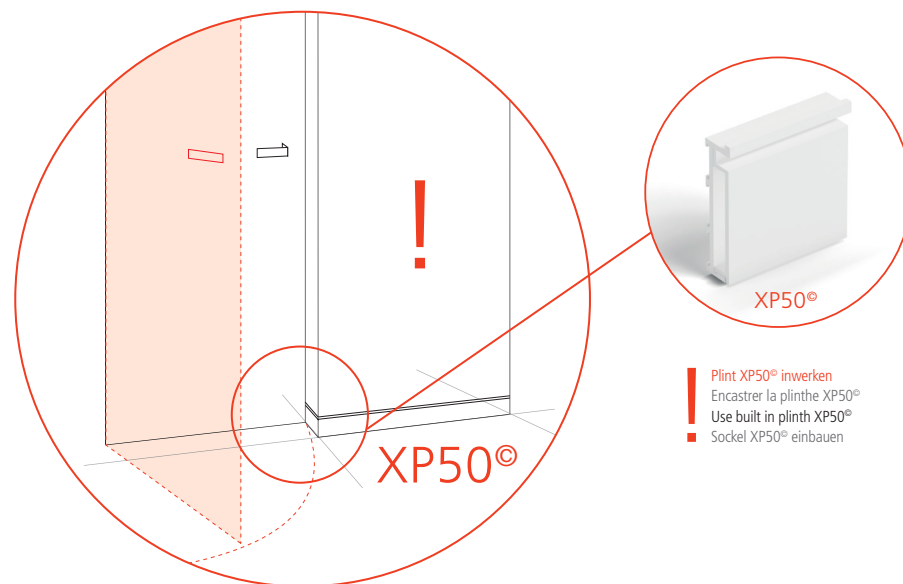

XP50®

! Plint XP50® inwerken  
Encastrez la plinthe XP50®  
Use built in plinth XP50®  
! Sockel XP50® einbauen



info@xinnix.eu  
www.xinnix.eu

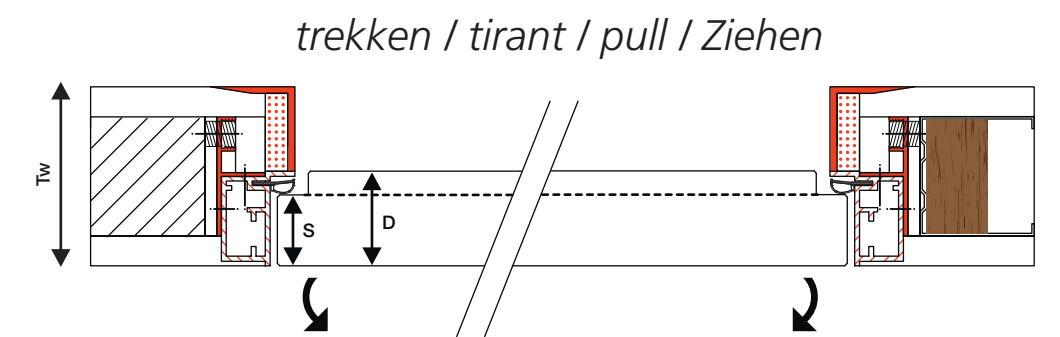
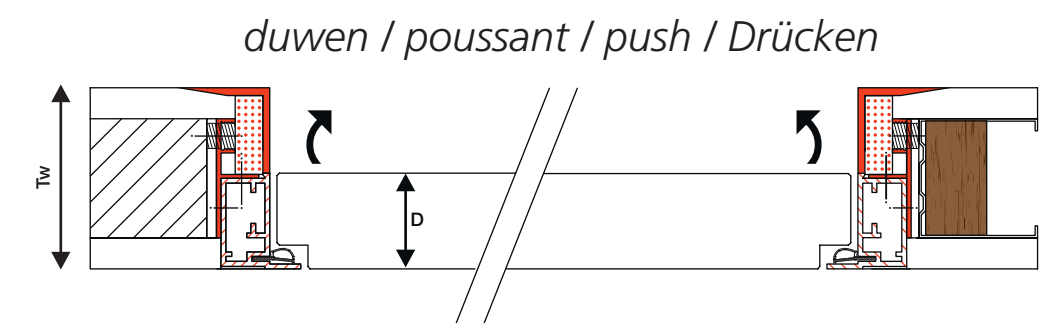

	S	D	Tw
X 40	33 mm	40 mm	≥ 70
X 45	38 mm	44-45 mm	≥ 75