

DATASHEET

SALTO ESD | Universal Energy Saving Device

The SALTO Universal ESD system allows hotels to optimize energy consumption by turning off lighting and adjusting climate control systems when guests are not in the room for long periods of time.

www.saltosystems.com

TECHNICAL SPECIFICATIONS: **UNIVERSAL ESD - ESDB**

SALTO
inspiredaccess



TECHNICAL DATA:

Dimensions (H x W x D):	90,2 x 53,30 x 57,50 mm
Weight:	183g
Housing	PC/ABS fireproof (according to norm UL94V-0)
Power supply:	52°
Consumption:	Nominal 30 mA, Maximum 50 mA (230 Vac)
Frequency	50 – 60 Hz.
Output relay:	2 Relays (free potential with 2 con- tacts NO / NC) Cutting power: 12 A, 230 V~,cos φ =1 8 A, 230 V~,cos φ = 0,6 Incandescent max. load: 10 A. Halogen max. load: 10 A. Cutting power max. in NC contact: 12 A, 230 V~,cos φ =1 8 A, 230 V~,cos φ = 0,4 Incandescent max. load.10 A. max. Halogen 10 A.
Pilots	Tricolour LED (amber, red, green)
Environmental conditions:	0 °C / +50 °C.
IP class:	Not suitable for outdoor use.
Certifications:	CE

TECHNOLOGY PLATFORMS:

SALTO SPACE:

Smile - Selfprogrammable	—
ROM:	—
SVN data-on-card:	•
SALTO RFnet:	•
SALTO BLUEnet:	•
SALLIS:	—

CONNECTION DIAGRAM:

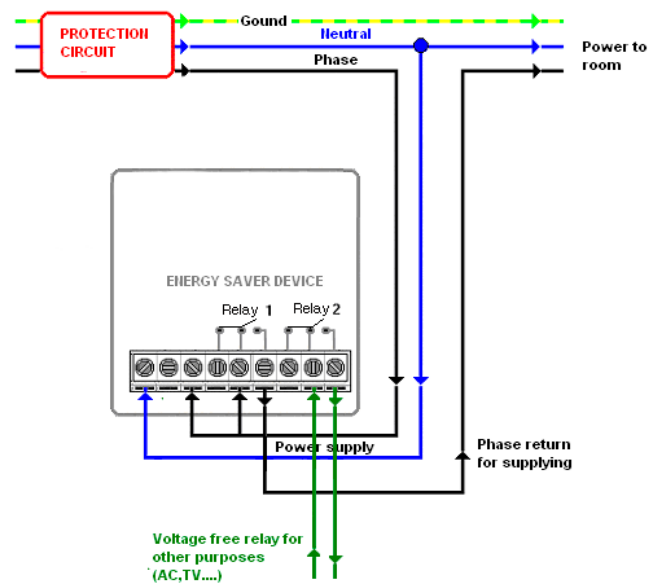

DATASHEET

SALTO ESD | Universal Energy Saving Device

The SALTO Universal ESD system allows hotels to optimize energy consumption by turning off lighting and adjusting climate control systems when guests are not in the room for long periods of time.

www.saltosystems.com

TECHNICAL SPECIFICATIONS:
UNIVERSAL ESD - FLUSH MOUNTED VOLUMETRIC SENSOR.

SALTO
inspiredaccess



TECHNICAL DATA:

Power:	1 Cr123a 3 v battery
Battery life:	5 Years (mean consumption 18ua, maximum 20ma)
Communications:	Wireless 2.4 Ghz, ieee 802.15.4
Communications coverage:	10 m (maximum distance to the energy saver)
Interface:	Red LED
Environmental conditions:	-40° to 60°
Technology:	Passive infra-red detector.
Detection coverage:	For a height of 12 m, an area of (32x28) m
Assembly height:	Maximum height 12 m
Thermostat precision:	Temperature: ±0.5° (15° To 40°), ±1° (0° to 60°)
Dimensions:	85 Mm x 37 mm
Weight:	90 gr

TECHNOLOGY PLATFORMS:**SALTO SPACE:**

Smile - Selfprogrammable	—
ROM:	—
SVN data-on-card:	•
SALTO RFnet:	•
SALTO BLUEnet:	•
SALLIS:	—

INSTALLATION: