

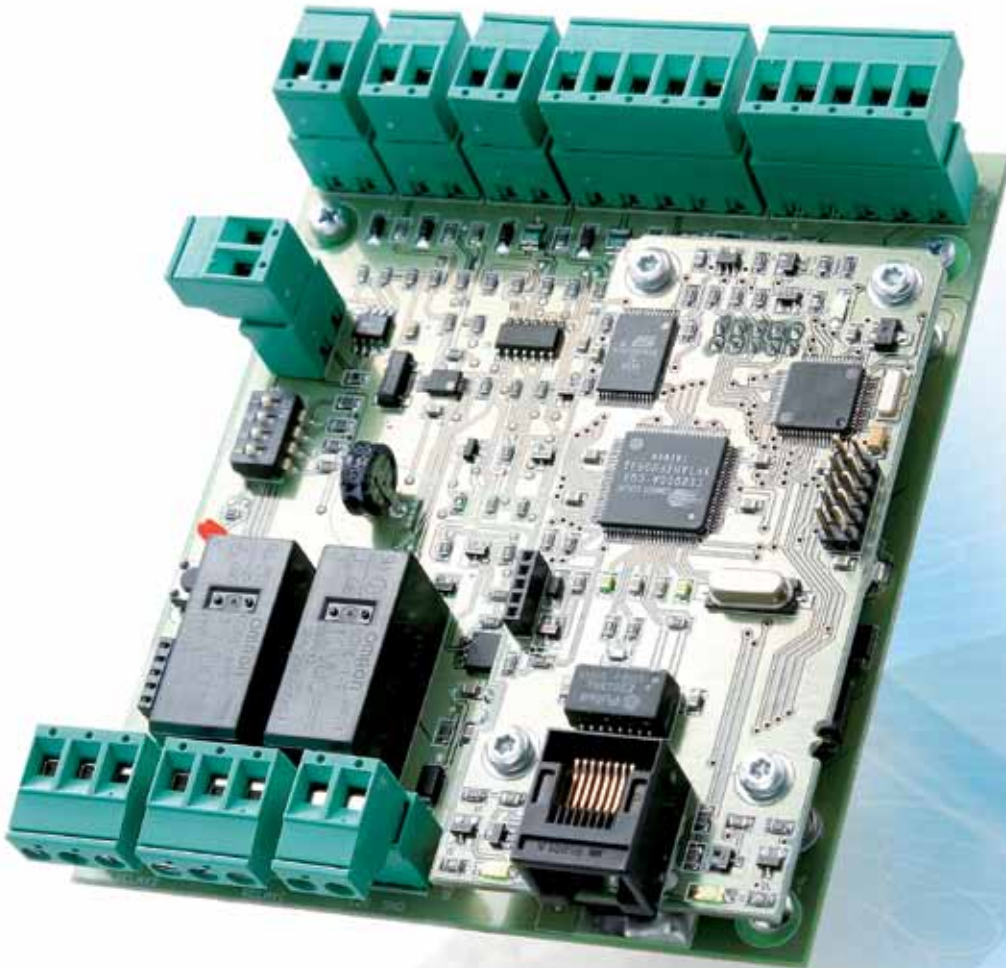

SALTO Systems I CU50EN

**SALTO**  
inspiredaccess



## CU50EN

The SALTO CU50EN is an on-line IP door controller that can have 1 or 2 wall readers connected and has 2 control relay outputs. Access control changes can be carried out on the door controller in real time. It provides full on-line features via the networked Ethernet/ WIFI link such as door monitoring status, remotely controlling door opening and Roll Call.



### ► Main features



- On-line IP door controller.
- Two wall reader connection, read in- read out locking, and has Anti Pass Back mode available by connecting 2 wall readers.
- Two relay output.
- Upgradable to CUENSVN.
- Compatible with SALTO relay extension board (EB5008) controlling up to 128 relay outputs suitable for elevators, etc.
- To be used with all SALTO wall readers (excepted WRM1000).
- Can be used with the SALTO WRMKP for dual identification (Carrier+PIN).
- Request to exit (RTE) switch input.
- Door monitoring and tamper monitoring via contacts input.
- Door state input.

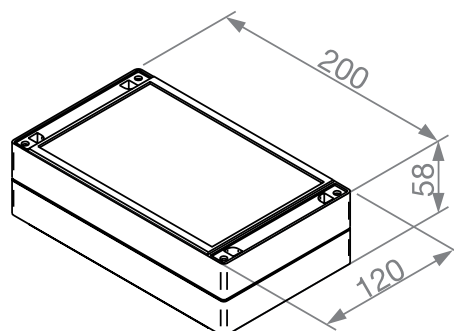
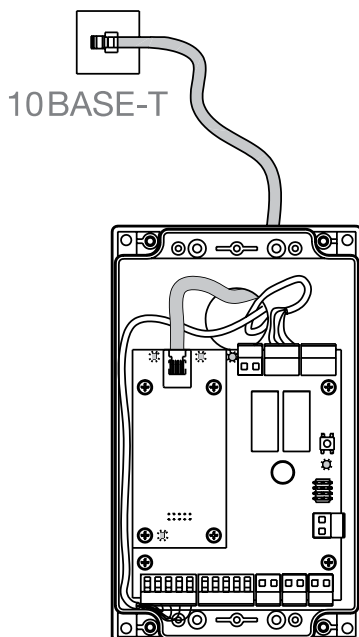

## ► On-line features



- Real-time access control changes:
  - Live monitoring of user entry and exit through the door controller.
  - Live audit trail build up on the software.
  - Door monitoring status for forced door and door left open alarm.
  - Remote door opening from software.
  - Door lock out or lock open emergency setting from software.
  - The IP door controller can be included in roll call set up used, for example for user location monitoring parking controls etc.
- Works as on-line hub up to on-line Energy Saving Devices.
- Connected to standard Ethernet/WIFI network.
- Works off-line if the network connection is lost.
- All the communications between the IP door controller and the PC are secured and encrypted. In addition the CU is protected by 3DES encrypted challenge / response for a higher security level.
- Invalidates deleted cards.

## ► Certificates



- CE EN55022 (1994), Class B
- CE EN 61000-6-1 (2001)
- CE EN 61000-6-2 (2001)
- CE EN 61000-4-2 (1995)
- CE EN 62000-4-3 (1995)
- CE EN 55024 (1998)



## ► About SALTO Systems:

Since its inception in 2001, SALTO Systems has grown to be the market leader in state-of-the-art electronic access control systems.

Recognising the need for a new access control concept, SALTO has developed a wide range of innovative products such as the SALTO Virtual Network and XS4 access control platform, while our electronic escutcheons, wall readers and on-line and off-line control units now control security access for a growing range of end users from Airports to Hospitals, Banks to Government Buildings and Universities to Hotels.

Our brand new HQ and high capacity manufacturing facility is fully equipped with the latest technology for JIT (Just in Time) manufacturing while substantial ongoing investment in a dedicated RD&I team (Research, Development and Innovation) enables us to stay at the cutting edge of modern mechanical, electronic and software design. This, together with ISO 9001:2008 and ISO 14001:2004 certification, ensures rigorous

quality management systems are in place to ensure the design, development and manufacturing of our electronic access control products always strive to achieve the highest possible standards of quality as required by you, our customers and for the environment.

Our distribution partner network now covers more than 70 countries to service international growth, and we have branch offices in Spain, UK, USA, Australia, Canada, Denmark, France, Finland, Germany, Holland, Mexico, Norway, Portugal, Singapore, Sweden and United Arab Emirates with more planned to open in other countries.

CONTACT:  
SALTO Systems HQ, Spain  
Polígono Lanbarren, C/ Arkotz, 9  
20180 Oiartzun, Spain

Tel.: +34 943 344 550  
info@saltosystems.com | www.saltosystems.com

**SALTO**  
inspired**access**

[www.saltosystems.com](http://www.saltosystems.com)

